

McGovern Medical School / School of Public Health Mini-Retreat

October 5, 2017



CCCT Mission

Mission - Coordination of multi-center controlled clinical trials.

Goal – To be the Academic Research Organization (ARO) within the TMC providing academic leadership to full-service clinical trial management capabilities, including clinical expertise, statistical analysis, data management, safety monitoring, site monitoring, and clinical events classification.

CCCT History

- Founded in 1971
- 25 NIH & industry multicenter clinical trials
- Phase I, II, III trials, sample sizes up to **42,000** patients, management of up to **800** sites
- ~\$250 million in funded projects
- ~\$300 million in others (SPRINT, PMI, ECHO)
- Leading role in clinical trials research
- Long history of **collaboration** with many academic and community institutions

CCCT Research Areas

- Cardiovascular diseases (hypertension, heart failure hypercholesterolemia)/stroke/kidney disease/stem cell therapy/ophthalmology/diabetes/sickle cell disease/trauma
 - **HDFP** (Hypertension Detection and Follow-up Program)
 - **BHAT** (Beta-Blocker Heart Attack Trial)
 - **SHEP** (Systolic Hypertension in the Elderly Program)
 - **ALLHAT** (Antihypertensive and Lipid-lowering Treatment to Prevent Heart Attack Trial)
 - **SAVE** (Survival and Ventricular Enlargement Trial)
 - **CARE** (Cholesterol and Recurrent Events Trial)
 - **CCTR** (Cardiovascular Cell Therapy Research Network)
 - **CRYO-ROP** (Cryotherapy – Retinopathy of Prematurity)
 - **GenHAT** – Genetics of ALLHAT

University of Texas School of Public Health – Houston
Coordinating Center for Clinical Trials
Clinical Trial Structure

Sponsor

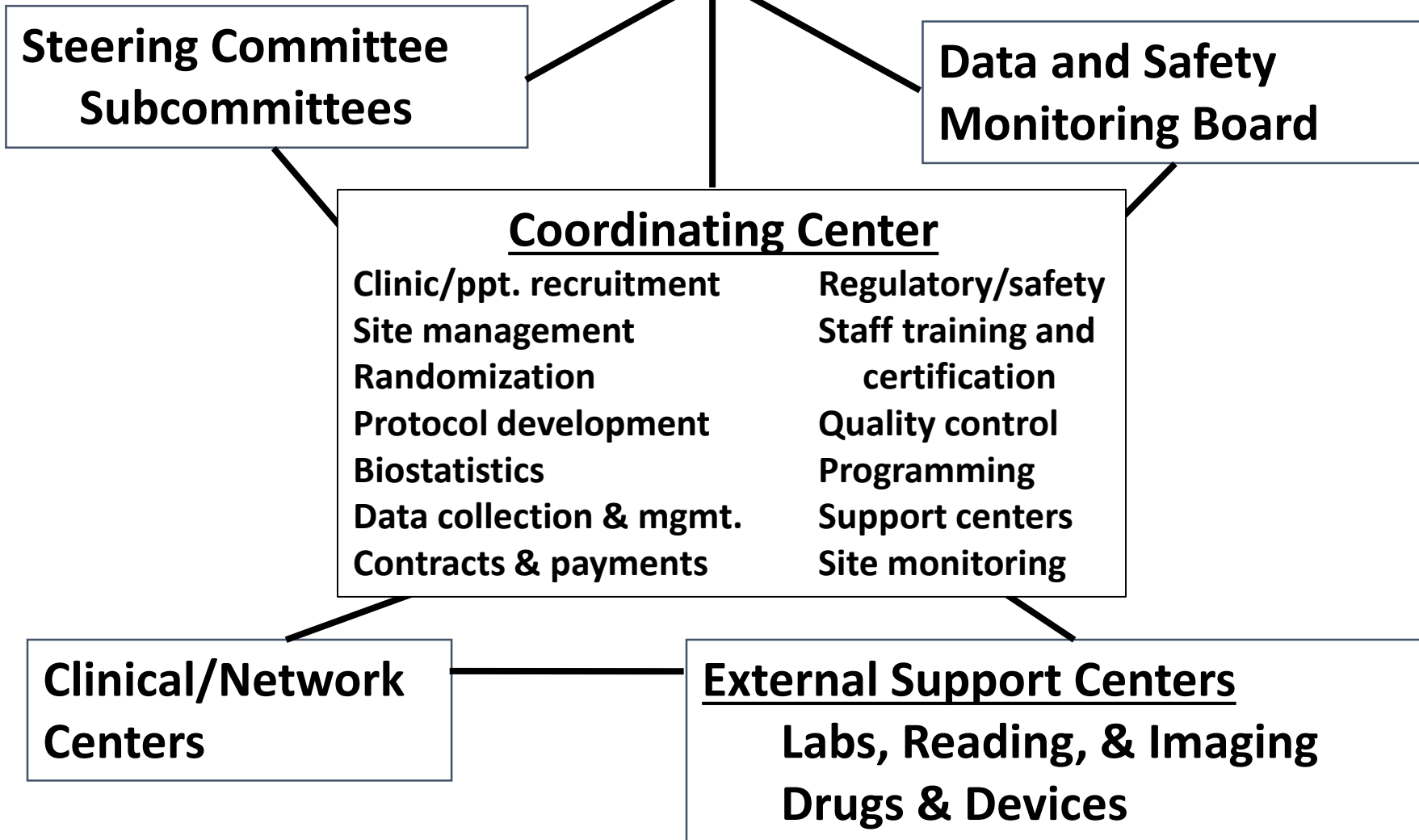

CCCT Impact

- Intellectual – 500+ publications, 70,000+ citations; 2002 ALLHAT JAMA paper , ISI Web of Science “one of the most cited recent papers in the field of Clinical Medicine”, H-index ~ 100
- Landmark trials - **changed** worldwide treatment of hypertension; major **impact** on preventing blindness in premature infants; **changed** practice of post MI treatment.
- Findings noted in **clinical guidelines** by national health organizations (e.g. – JNC 5-8); reviews; educational materials

The world’s largest medical center should have an ARO like the Duke Clinical Research Institute (annual operating budget of \$200 million).



Program Evaluation

Christine Markham, PhD

Associate Professor & Associate Department Chair

Associate Director, Center for Health Promotion & Prevention Research



School of Public Health

Health Promotion
and Behavioral Sciences





Levels of Program Evaluation

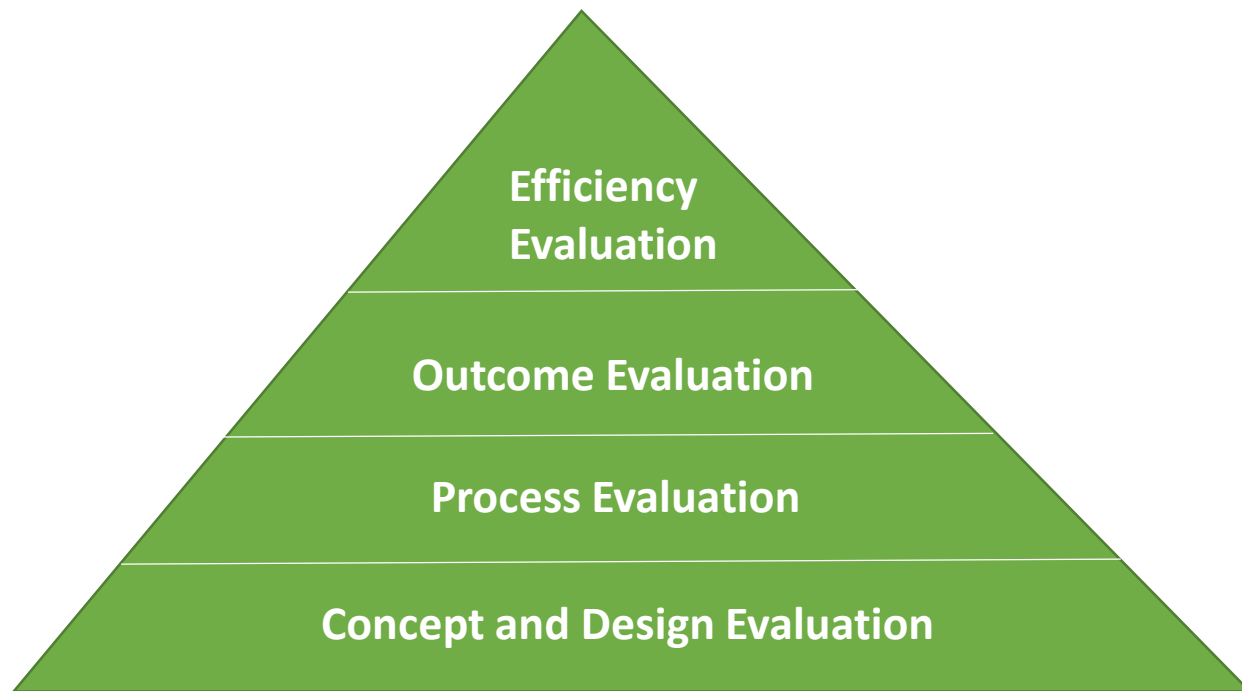



Study Designs, Settings & Funding Agencies

Study Designs

- Randomized Clinical Trials
 - Individual level randomization
 - Cluster randomized controlled trials
 - Multisite trials
- Adaptive Interventions & SMART Designs
- Comparative Effectiveness Designs
- Hybrid Designs
- Time Series Designs

Settings

- Hospitals
- Clinics
- Schools
- Homes
- Community settings

Funding Agencies

- NIH, CDC, PCORI, CPRIT, DHHS
- Philanthropic foundations



Example Studies

Principal Investigator	Title	Funding Agency
Maria Fernandez	Patient, Stakeholder Engagement in a Safety-Net Healthcare System Preliminary Formative Research	PCORI
Sally Vernon	Multi-component interventions for patients & providers to increase HPV vaccination in pediatric clinics in Houston	CPRIT
Paula Cuccaro	Using social marketing and mobile school-based vaccination clinics to increase HPV vaccination uptake in high-risk geographic areas	CPRIT
Lara Savas	A community based program to increase breast and cervical cancer careening among Latino women	CPRIT
Maria Fernandez	Increasing Reach and Implementation of Evidence Based Programs for Cancer Control	NIH R01
Melissa Peskin	Cluster randomized trial of school based program to prevent teen dating violence	NIH R01
Kayo Fujimoto	YMAP: Young Men's Affiliation Project of HIV Risk and Prevention Venue	NIH R01
Belinda Hernandez	Impact of MiCare Implementation on Patient Centered Medical Home Effectiveness Measures	Department of Air Force

Genomics & Bioinformatics

Alanna C. Morrison, PhD

Director, Human Genetics Center

Professor & Chair, Department of Epidemiology,
Human Genetics, and Environmental Sciences

Human Genetics Center

Center for Demographic and Population Genetics (CDPG)

Founded
1971

AJHG

CDPG
moved to
GSBS Bldg.
1978



Dr. Eric Boerwinkle,
Director

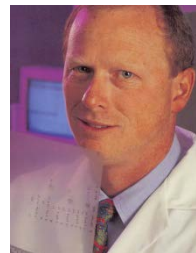

1998



2013



1973
First
CDPG
manuscript
published



1994
CDPG
renamed
HGC
under SPH

1997
Masatoshi Nei
inducted
to NAS

2003
Wen-
Hsiung Li
Inducted
to NAS



2007

2016
Dr. Alanna
Morrison,
Director



Dr. William (Jack) Schull,
Founder and Director

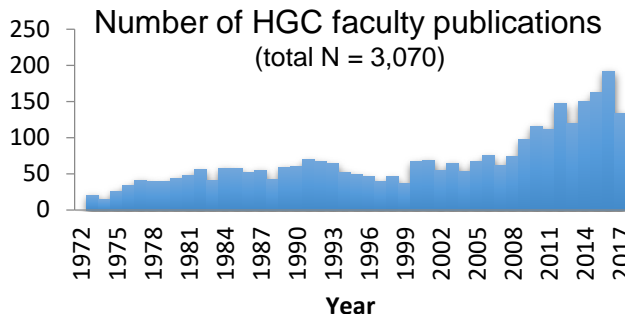
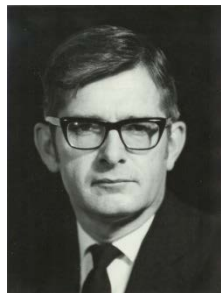

Resources Benefiting Collaborative Research Projects

Genomic Services

- Genotyping
- Epigenetics
- Sample Handling
- Biorepository

Analytic Support

- Genome-Phenotype Relationships
- Bioinformatics

Training

- Certificate in Genomics & Bioinformatics

Genotyping Services

Platforms

Low- to High-Throughput Applications

- TaqMan allelic discrimination and quantitative PCR
- Agena Bioscience MassARRAY
- Illumina Infinium arrays
(GSA, Omni, Exome, Core, MEG, custom and various others)
 - Largest genotyping array project N~62,000
 - Processed > 140,000 arrays
- Robust sample handling, genotyping, and quality control procedures

Samples processed with LIMS in the last 5 years

Year	# of Samples
2013	212,352
2014	24,381
2015	26,688
2016	62,976
2017	47,616
Total	374,013

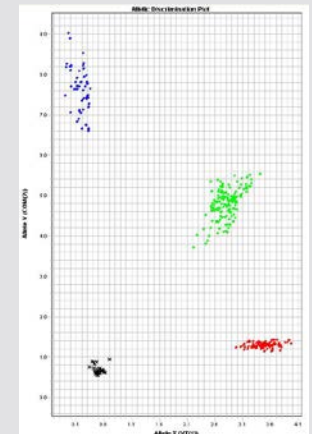
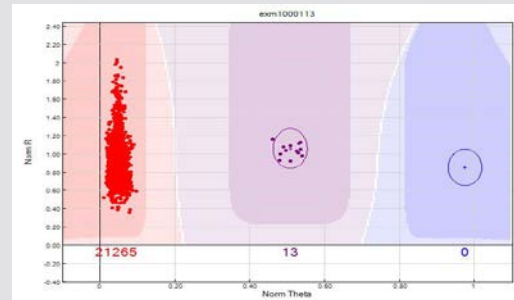

Epigenetic Services

Platforms

- Illumina MethylationEPIC arrays for epigenome-wide coverage
- Agena Bioscience EpiTYPER chips for targeted CpG sites

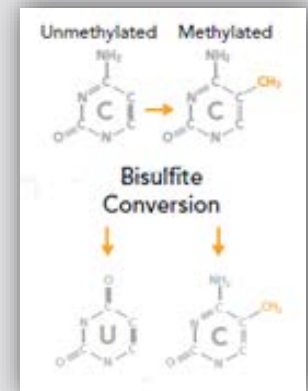
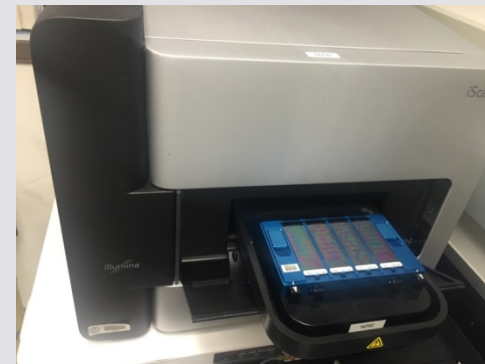
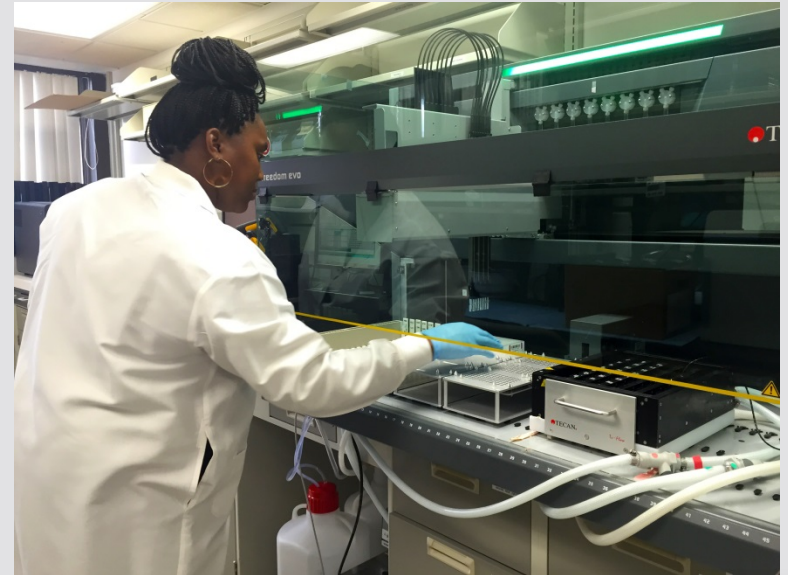

Sample Handling & Biorepository Services

DNA

- Extraction & quantification
- Whole genome amplification
- FFPE repair
- Bisulfite conversion

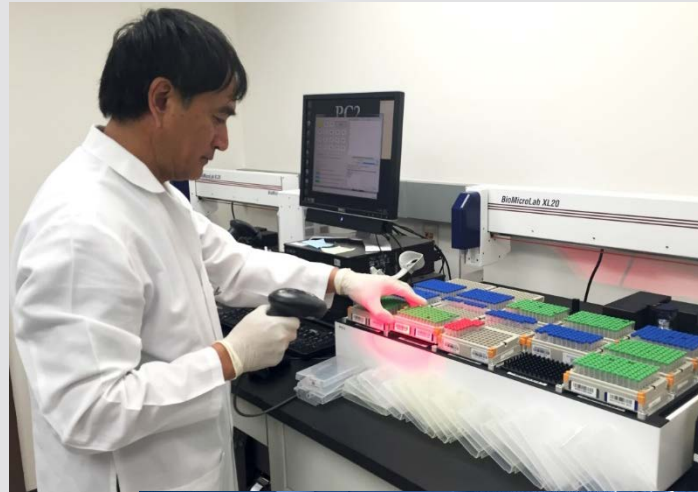

RNA

- Extraction
- Globin depletion for sequencing



Storage

- Two freezer farms (SPH and OCB)
- 126 units with >1M specimens
- Controlled badge access, temp monitoring 24/7 with call down procedures, above 500 year flood plain, and emergency power



Computing Infrastructure

- Facilitates sample processing in the lab
- Powerful computing network for conducting large-scale genomic and bioinformatics analyses
- Interface with cloud computing environments

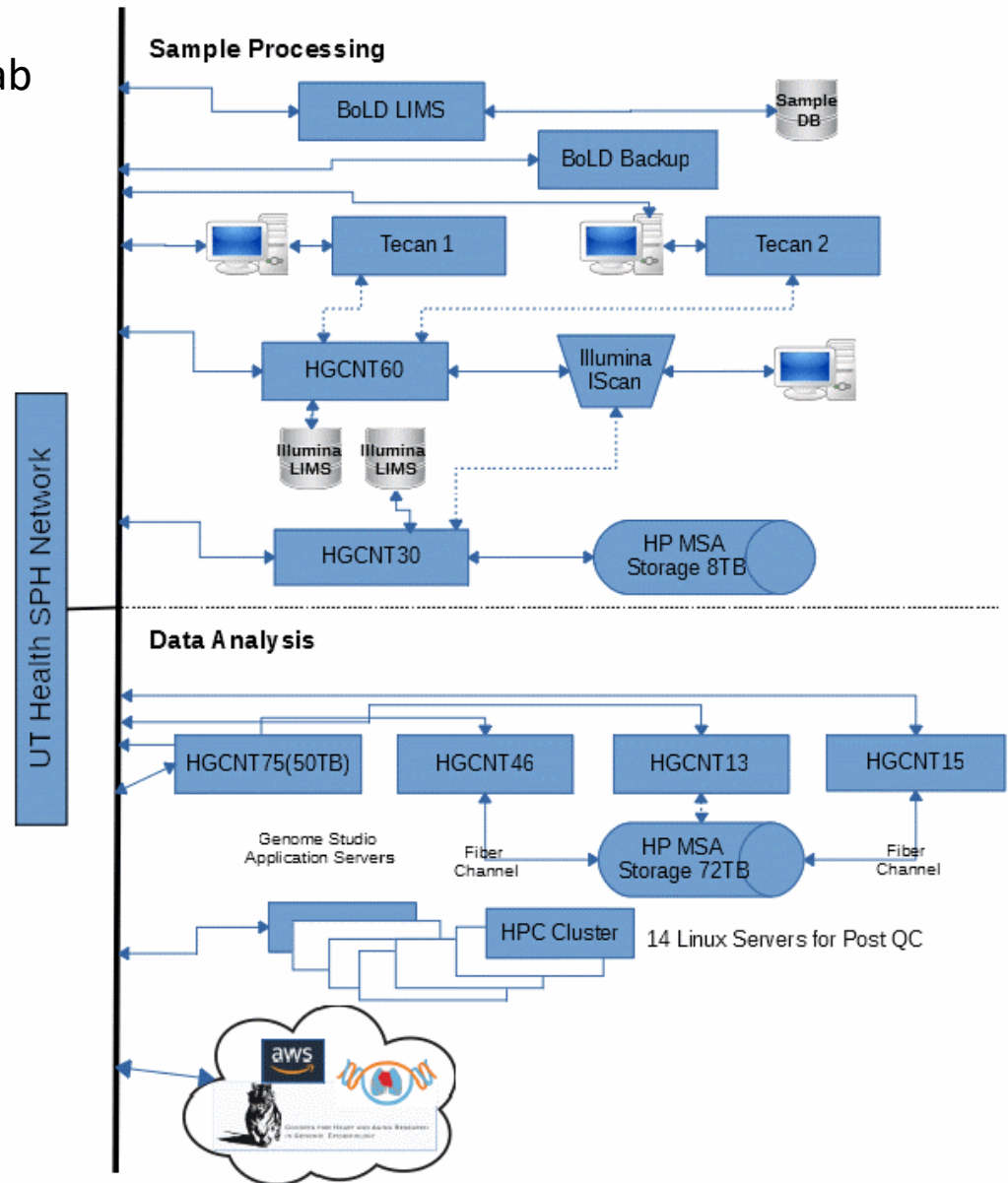

Genomics & Bioinformatics

Analytic Support

- Population-, clinical-, and family-based studies
- GWAS, EWAS, exome, and whole genome sequence analyses
- Using bioinformatics to evaluate genomic variation and visualize its contribution to health and disease
- Precision Health: overall goal of using information about an individual's genetic make-up, in combination with data about health experience and habits, to speed scientific discoveries that will impact personal health

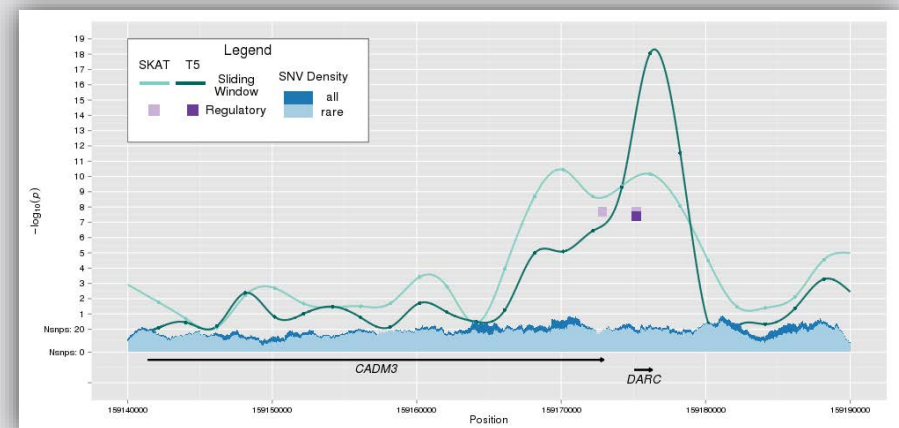
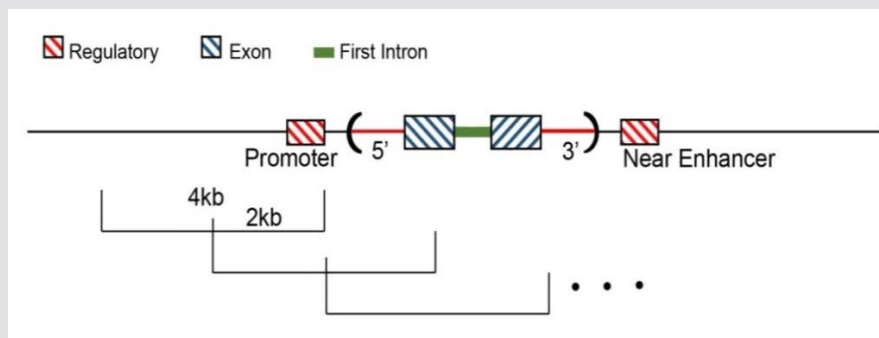

Training

Certificate in Genomics & Bioinformatics

- Enable a generation of investigators to integrate genomic and related high-dimensional data seamlessly into population and personalized health.
- The certificate is intended for any individual who wishes to obtain practical knowledge in human genetics, genomics, clinical genetics, and bioinformatics.
 - Four courses (12 credits)
 - Completed in 1 year
 - Obtain the unique set of skills needed to assess, manage, and analyze large-scale genomic, phenotypic, and other molecular measurements.

<https://sph.uth.edu/academics/graduate-certificate-programs/>

Center for Healthcare Data

Cecilia Ganduglia-Cazaban

Assistant Professor

Department of Management, Policy and Community Health

Gift BCBSTX 2010

Medicaid 2013

TDI 2014

TRUVEN 2015

MULTIPLE DATASETS
2016-2017

BCBSTX	2008-2016	Claims 2.3-4 M/year	Texas
Colorado APCD	2009-2015	Claims 1.5-3.5 M/year	Colorado
Truven Mkscan	2011-2015	Claims 28-55 M/year	National
Truven HPM	2011-2015	productivity data	National
Medicaid	2008-2012	MOU signed for data refresh	Texas
Medicare	2010-2013	QE cert. expect refresh & MOU 12/17	Texas
THCIC	2008-2016	all hospital discharges (inpx/outpx)	Texas
TWCC	2005-1stQ2017	workers comp. for work related injuries	Texas
CERNER	2000-2016	E.H.R 1.2M-25M patients in a year	National
UTP	2013-2016	Billing & E.H.R	Houston
ERS	2014-2016	Claims	Texas

Putting data to work... and opportunities

- ✓ Initial certification as a CMS Qualified Entity:
 - Medicare claims data + another dataset for provider performance. Public Reporting on Cost and Quality (regional).
 - QEs may also create, provide, or sell analyses to other entities or users/researchers.
 - Partnering with Texas providers, Texas Medical Association. (NRHI-RWJF grant)
- ✓ Service to the Texas Department of Insurance on Price Transparency.
- ✓ All Payer Claims Data Base: APCD for Texas
- ✓ Texas Employee Health Plans analysis and recommendations for value based care.
- ✓ Agreement with HHSC to share Medicaid data and provide analysis relevant to improving the health and quality of care of Texas' Medicaid population.

Putting data to work... and opportunities

- Secure servers, analytical software, trained team in administrative data and programming.
- Already established collaborations with partners within SPH, UT-HSC, other universities.
 - CMS-AHC
 - TNP
 - HPV cost of care
 - Nephropathy
 - AKI
 - Migraine/ MS
- Spring course “Administrative data in Health Services Research”

How to apply

<https://sph.uth.edu/divisions/management-policy-comm-health/chcdr/>

- LOI
- Define dataset that will be needed
- Proposal/IRB/(depending on source: owner approval)/ sign DUA
- *Investigators* : PI Name, Title, Organization and contact information.
- *Research Protocol*: 2,000 word summary of your protocol:
 - A. Statement of the research question and why use the specific claims data in the project
 - B. How the work will be done
 - I. Background and significance
 - II. Specific aims
 - III. Research design and methodology
 - IV. Dissemination plans
 - C. Procedures that will be followed to maintain the confidentiality of the data and IRB process
 - D. Work/plan and timeline
 - E. Intended source of research funding



Department of Biostatistics & Data Science

Hulin Wu, PhD

The Betty Wheless Trotter Professor & Chair

Department of Biostatistics & Data Science

Professor of Biomedical Informatics

**University of Texas Health Science Center at
Houston**

Integrated Biostatistics and Data Support

One-Stop Services

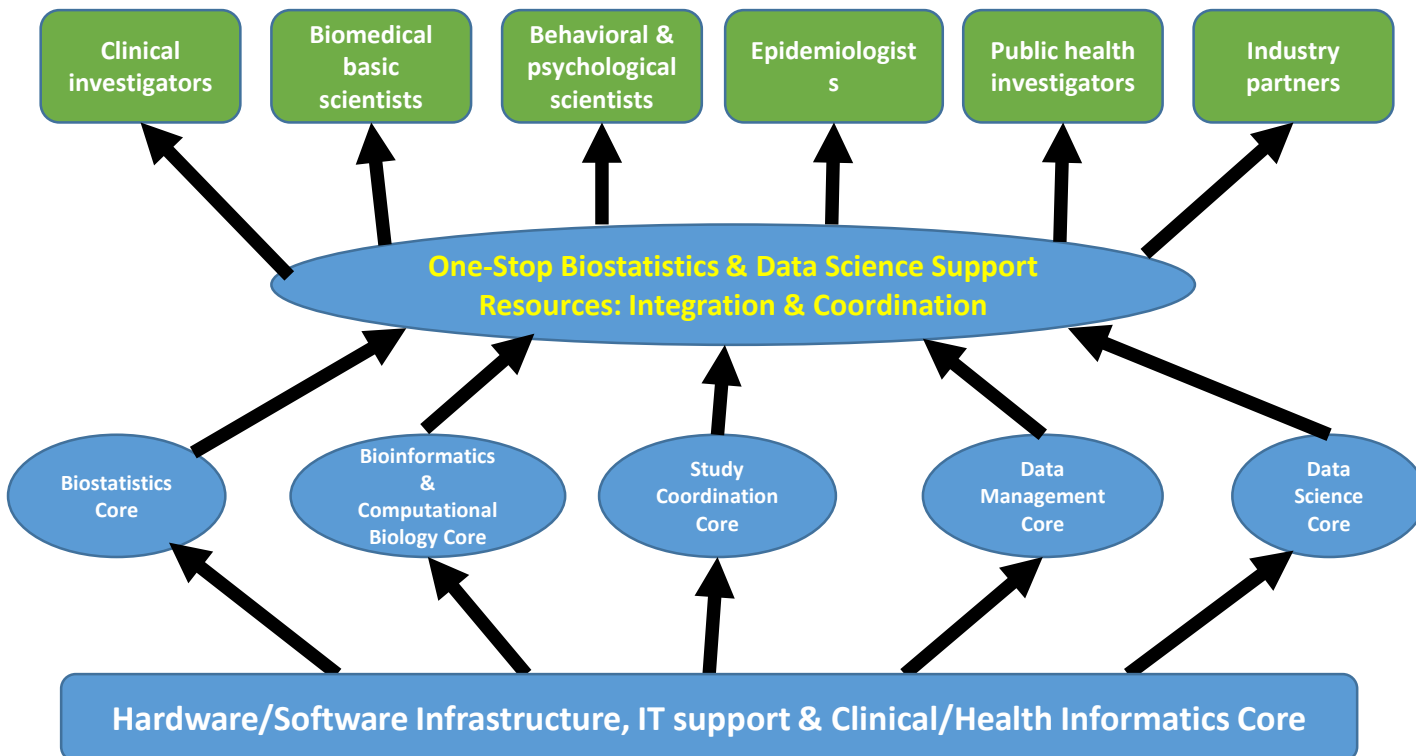

Data Services

- 1. Identify relevant existing data from public and other resources for your project**
- 2. Perform data management, data extraction and data preparation for your project**
- 3. Preliminary data analysis and exploration for grant applications**
- 4. Support experimental design for new data collection**
- 5. Support data sharing**

Biostatistics & Advanced Data Analytics

- 1. Sample size calculation and study design**
- 2. Statistical data analysis**
- 3. Bioinformatics (“omics”) data analysis**
- 4. Computational and biomathematical predictive modeling**
- 5. EHR/EMR and other health care data integration/analytics**
- 6. Imaging data analysis and modeling**
- 7. Wearable device stream data analysis and modeling**
- 8. Unstructured and qualitative data analysis**
- 9. Complex data visualization**
- 10. Data analysis/modeling/integration software tool development**

Big Data Research Platform

- Not only bring **data analysis skills** to biomedical/health science investigators
- But also bring the **clean data/Big Data resources** to biomedical/health science investigators

Big Data Resources

Database	Data Type	Sample Size	Owner	Data Host	Easy Access?	Easy for Research?
GEO	Genetics	n=2.2M	NIH	Public	Excellent	Excellent
UK Biobank	Epi Obs	n=0.5M	UK Biobank	SPH	Poor	Very good
Cerner	EHR	n=50M	Cerner	SBMI/SPH	Very good	Excellent
BCBS	Insurance	n=10M	BCBS	SPH	Poor	Poor
Truven	Insurance	n=80M	Truven	SPH	???	???
Medicaid	Insurance	n=69M	HHS/CMS	SPH	???	???
.....						

Prevention, Preparedness & Response (P2R) Academy

Janelle Rios, PhD, MPH
Director, Public Health Practice
Co-Director, P2R Academy

P2R Academy

- To provide prevention, preparedness and response training in anticipation of hazards and disasters
- Collection of health and safety experts
- In-person and online delivery methods
- Primary funding sources
 - NIH/NIEHS Award No. U45ES019360
Texas-Utah Consortium
 - Hazardous Waste Worker Training
 - HazMat Disaster Preparedness Training
 - NIH/NIEHS Award No. UH4ES027055
Biosafety and Infectious Disease Training Initiative (BIDTI)
- www.p2rAcademy.org

Prevention & Preparedness Activities

- Preparedness Exercises
- Chagas Disease
- Biosafety Journal Club
- Hazardous Materials Management
- Biosafety Officer
- Stop the Bleed Training and Service



Logo: Homeland Security



T. Cruzi

Response Activities

- Ebola Virus Disease → Fundamentals Infectious Diseases of Public Health Consequence
- Hurricane Harvey → Outreach, Just-in-time short courses (flood cleanup, mold abatement, respirator use), online infectious disease course, distribution of educational materials and donated personal protective equipment, and lots of meetings with lots of different people



Photo: Terry Vine



Photo: Fe y Justicia Worker Center



Student Activities



Student Epidemic Intelligence Service (SEIS)
Impromptu Meeting, 9/14/17



Emergency Preparedness and Response to
Biological Threats Symposium, 9/27/17
Texas National Security Network, UT System
Galveston National Laboratory

Opportunities to collaborate

www.p2racademy.org

Janelle.Rios.utn.tmc.edu



Intervention Development, Community Engagement and Implementation Science

Maria E. Fernandez, PhD

Professor, Health Promotion and Behavioral Science

Director, Center for Health Promotion and Prevention Research



School of Public Health

Health Promotion
and Behavioral Sciences



Intervention Development : A Process Too Often Haphazard



ISLAGIATT
principle

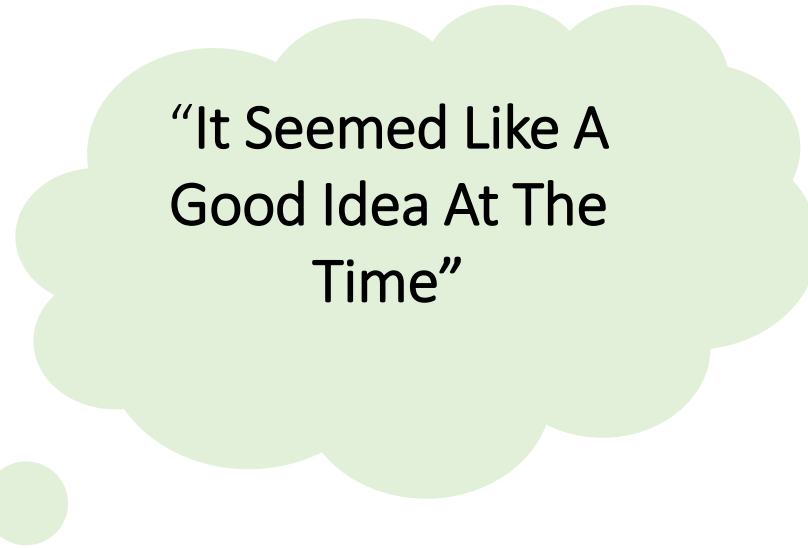

“It Seemed Like A
Good Idea At The
Time”

Intervention Development: We wrote the book ...literally

Intervention Mapping: A Systematic Approach for Program, Development, Implementation and Adaptation

1. Helps design multilevel interventions in ways that enhance its potential for use
2. Guides the design of dissemination interventions (strategies) to influence adoption, implementation and continuation
3. IM processes can guide adaptation of existing evidence-based interventions

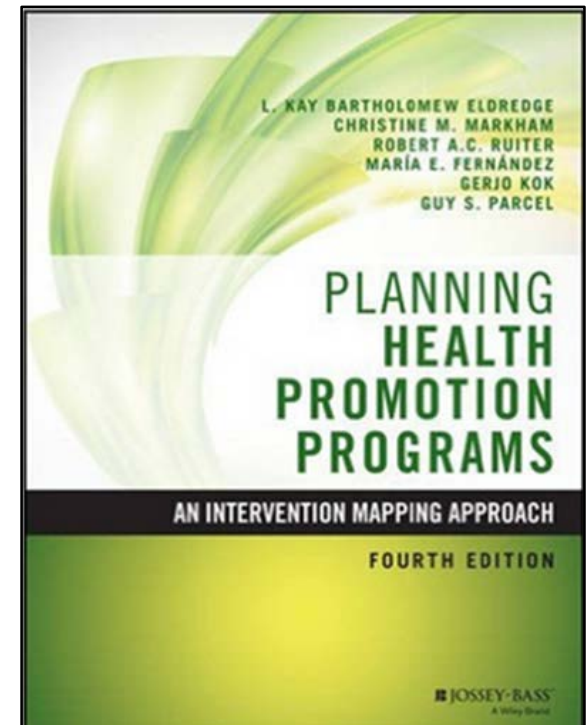

Intervention Mapping Applied

Health Domains

- Chronic disease management
- Obesity prevention
- Cancer prevention and control
- HIV, STI & pregnancy prevention
- Injury prevention
- Mental health
- Substance use prevention
- Breast feeding
- Sun protection
- Violence prevention
- Flu vaccination

Settings

- Schools
- Homes
- Healthcare settings
- Worksites
- Communities

Populations

- Children & adults
- Elderly
- Migrant workers
- Injecting drug users

Engaging Communities to Increase Research Relevance and Reach

Community engagement can:

- Increase accurate and culturally appropriate data collection, intervention development, implementation, data analysis, and interpretation of findings;
- Provide resources and benefits to community;
- Facilitate effective dissemination of findings to impact public health and policy;
- Increase the potential for translation of research into sustainable change

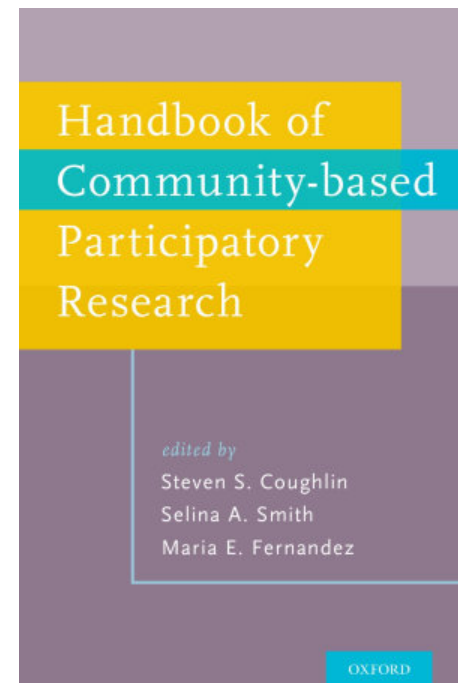

CBPR across the Translational Science Research Continuum

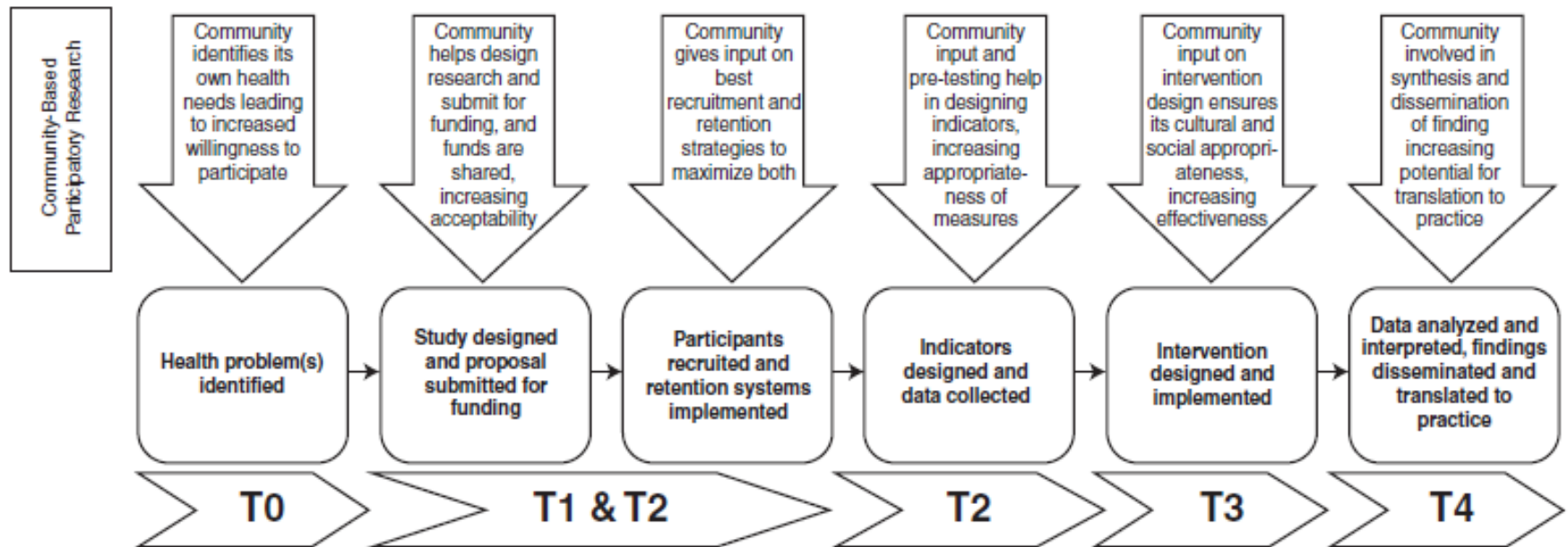



Implementation Science: Moving Research to Practice

“Closing the gap between research discovery and program delivery is both a complex challenge and an absolute necessity if we are to ensure that all populations benefit from the Nation’s investments in new scientific discoveries.”
(National Institutes of Health)

The field of **Implementation Research** seeks to close this gap:

“supports the movement of evidence-based interventions and approaches from the experimental, controlled environment into the actual delivery contexts where the programs, tools, and guidelines will be utilized, promoted, and integrated into the existing operational culture” (Rubenstein, 2006)

Conceptual Model for Implementation Research

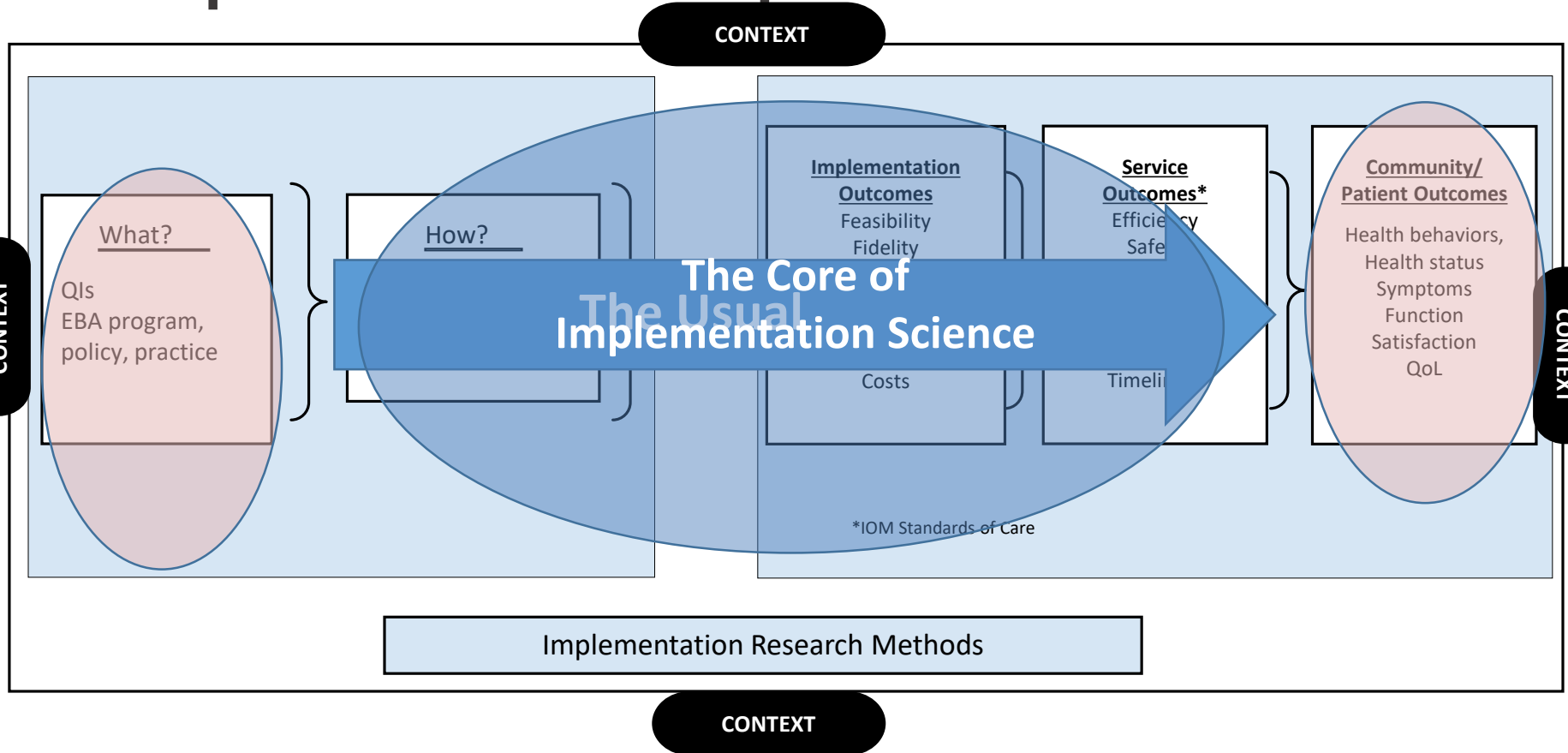

Adapted from Proctor et al 2009 Admin. & Pol. in Mental Health Services



```
graph LR; A[Discovery] --> B[Intervention Development/Testing]; B --> C[Delivery]
```

Discovery

Intervention
Development/Testing

Delivery

Understanding Behavioral and Contextual Factors Influencing Cancer Health Disparities

- Studies to better understand factors influencing breast, cervical, and colorectal cancer screening and HPV vaccination among low-income Hispanics

Example: HPV Vaccination

- Studies of HPV knowledge, beliefs, and cultural factors on HPV vaccination
- Communication studies to identify best strategies for framing messages
- Studies to develop measures to assess psychosocial factors
- Studies to understand provider recommendation
- Studies to identify system level influences of vaccination
- Multi-level conceptual model for understanding HPV vaccination decisions



- HPV vaccination
- Sexual Health (STI and pregnancy prevention)
- Cancer Screening
- Violence Prevention
- HIV prevention and management
- Epilepsy
- Obesity Prevention and treatment
- Childhood vaccination
- Physical Activity
- Nutrition
- Asthma





Dissemination and Implementation Research

In Community Health Centers

- Factors influencing implementation of practice change in CHCs
- Measurement development – Consolidated Framework for Implementation Research, Interactive Systems Framework, Organizational readiness
- Development of implementation strategies to increase prevention and treatment
 - Implementing practice change for HPV Vaccination; 3 CPRIT funded studies: Legacy, Texas Children's Pediatric clinics
 - Increasing implementation of BP guidelines, Sickle Cell Disease Management guidelines
- Social Network Analysis of organization adopting EBI

Social Service Agencies (United Way's 211 Program)

- Linking 211 callers to cancer control services
- Smoke Free Homes

Tools to enhance adaptation and implementation of evidence-based interventions

- IM Adapt Online

Opportunities to Collaborate!

Maria E. Fernandez PhD

Maria.E.Fernandez@uth.tmc.edu

713-500-9626

